



**LANXESS**

**2004 Full Year Results Conference**

**April 26, 2005**

## Disclaimer

This document does not constitute an offer or invitation to purchase or subscribe for any securities, and neither this document nor anything contained herein shall form the basis of or be relied upon in connection with any contract or commitment whatsoever. In particular, these materials are not an offer for sale of securities in the United States. Securities may not be offered or sold in the United States absent registration or an exemption from registration under the U.S. Securities Act of 1933, as amended. Neither LANXESS AG nor Bayer AG intends to register any securities of LANXESS AG in the United States or to conduct a public offering of securities in any jurisdiction, including the United States. The listing of the Company's shares on the official market of the Frankfurt Stock Exchange (Prime Standard) is based on a listing prospectus published by the Company.

Neither this document nor any copy of it may be taken or transmitted into the United States or distributed in the United States. Any failure to comply with this restriction may constitute a violation of the U.S. securities laws.

This document is being distributed in the United Kingdom only to investment professionals falling within article 19(5) of the Financial Services and Markets Act 2000 (Financial Promotion) Order 2001 (the "Order"), high net worth companies, and other persons to whom it may lawfully be communicated, falling within Article 49(2)(a) to (d) of the Order.

The distribution of this document in other jurisdictions may also be restricted by law, and persons into whose possession this document comes should inform themselves about, and observe, any such restrictions.

Please note that this Presentation (including any information contained herein and any information, whether or not in writing, supplied in connection therewith) is strictly confidential.

This Presentation has been prepared by LANXESS AG (the "Company") and is furnished to you solely for your information and may not be reproduced or redistributed, in whole or in part, to any other person.

No representation or warranty (express or implied) is made as to, and no

reliance should be placed on, the fairness, accuracy or completeness of the information contained herein and, accordingly, none of the Company or any of its parent or subsidiary undertakings or any of such person's officers, directors or employees accepts any liability whatsoever arising directly or indirectly from the use of this document.

This Presentation contains certain forward-looking statements, including assumptions, opinions and views of the Company or cited from third party sources. Various known and unknown risks, uncertainties and other factors could cause the actual results, financial position, development or performance of the company to differ materially from the estimations expressed or implied herein. The company does not guarantee that the assumptions underlying such forward looking statements are free from errors nor do they accept any responsibility for the future accuracy of the opinions expressed in this Presentation or the actual occurrence of the forecasted developments.

No representation or warranty (express or implied) is made as to, and no reliance should be placed on, any information, including projections, estimates, targets and opinions, contained herein, and no liability whatsoever is accepted as to any errors, omissions or misstatements contained herein, and, accordingly, none of the Company or any of its parent or subsidiary undertakings or any of such person's officers, directors or employees accepts any liability whatsoever arising directly or indirectly from the use of this document.

By accepting this Presentation you acknowledge that you will be solely responsible for your own assessment of the market and the market position of the Company and that you will conduct your own analysis and be solely responsible for forming your own view of the potential future performance of the Company's business.

This Presentation speaks as of April 26, 2005. Neither the delivery of this Presentation nor any further discussions of the Company with any of the recipients shall, under any circumstances, create any implication that there has been no change in the affairs of the Company since such date.

The logo for LANXESS, featuring the word "LANXESS" in a bold, black, sans-serif font. A red horizontal line is positioned beneath the letters "ANXESS".

# Agenda



- 1. Review of 2004**
- 2. FY 2004 Financials**
- 3. Strategy and Restructuring**
- 4. Outlook**

# Margins Continue to Lag Behind Competitors Despite All Positive Developments

## EBITDA Margins 2004\*

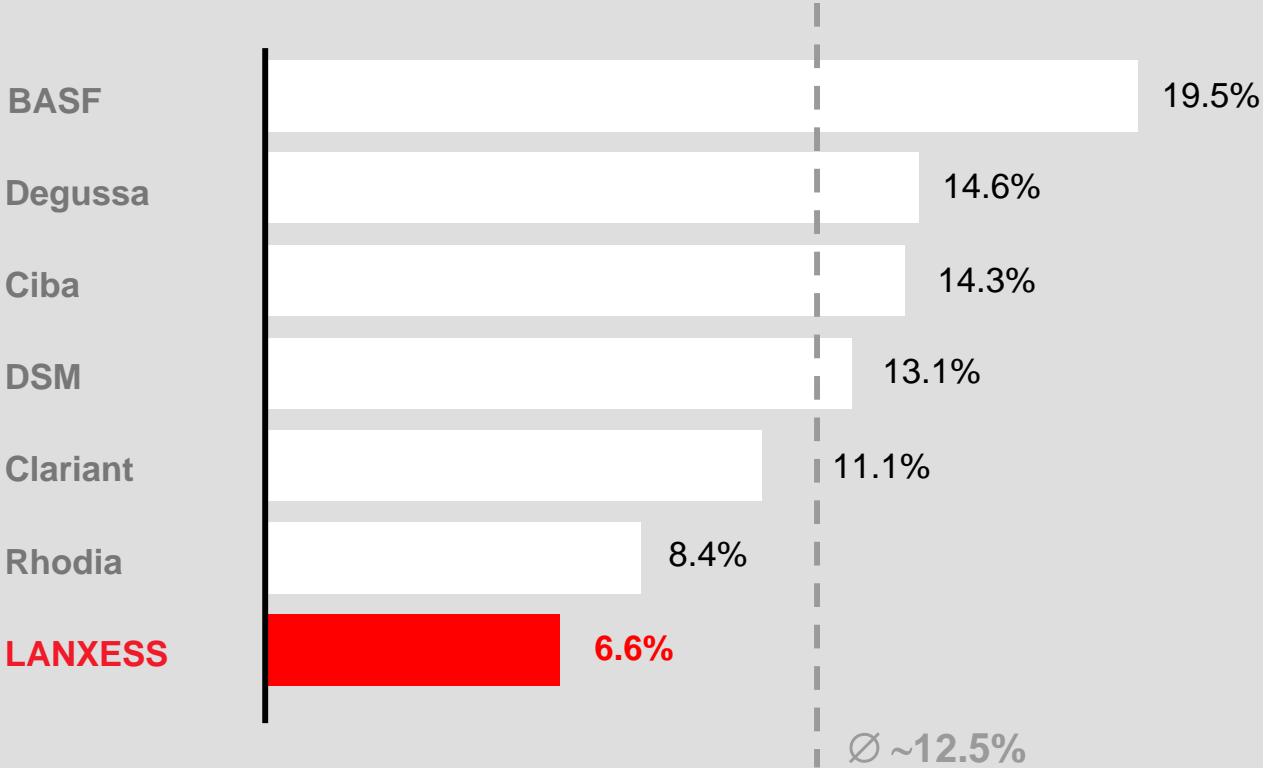

\* EBITDA pre exceptionals in % of sales FY 2004;  
Source: annual reports

# Major Challenges Overcome in 2004

## LANXESS established as a unit

- Several major areas addressed in parallel within one year
  - Spin-off
  - Structure
  - Listing
- Each of them a challenge in itself
- Essential to maintain at least the previous level of business

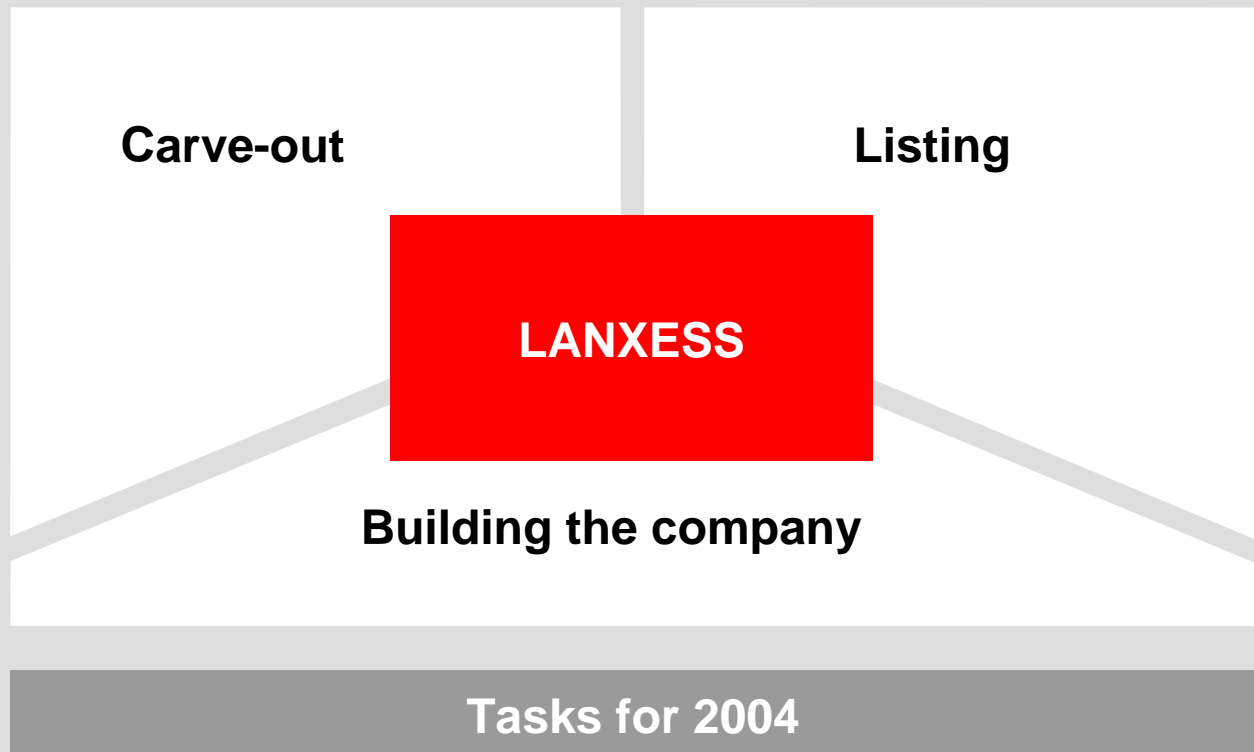

# LANXESS Inherits a Difficult Legacy

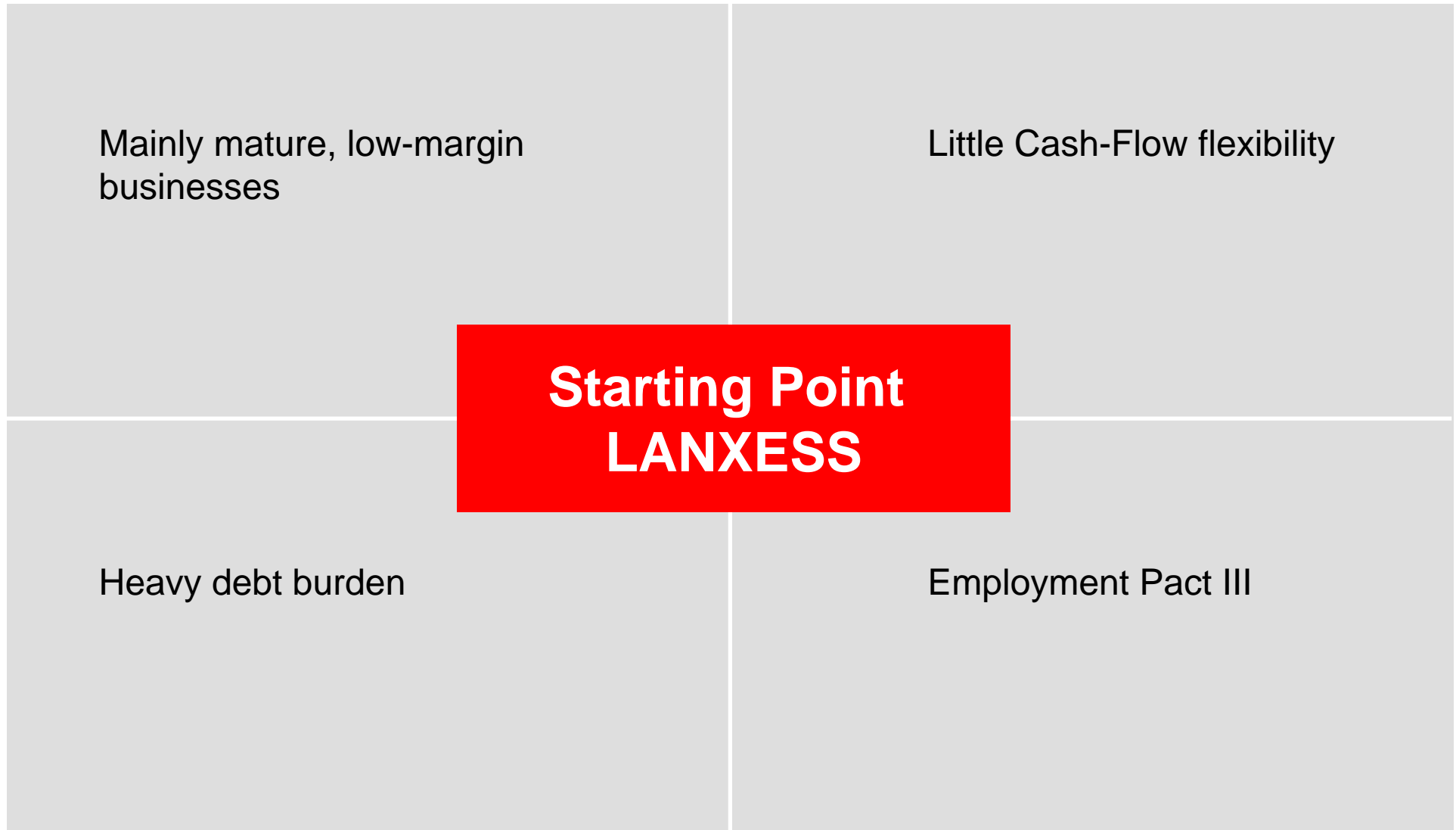

# Major Tasks Determined by Starting Position

**Improve performance**

**Reduce costs**

**Focus on profitable businesses**

# Action Taken Immediately

Improve performance

Reduce costs

Focus on profitable businesses

## Highlights 2004

- Transparent organization
- Responsibilities clearly defined
- New price/volume strategy
  
- Restructuring
- Reduction in personnel costs  
(pay components above collectively agreed rates)
  
- Lean asset strategy in Asia
- Creative partnership solutions
- Debottlenecking in Butyl Rubber



# Improvements in 2004 over 2003

## Sales

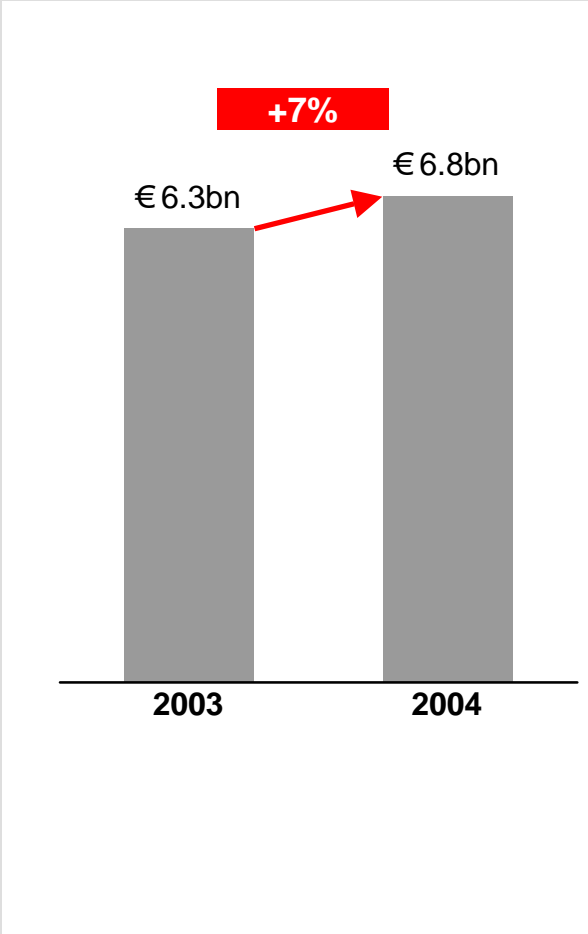

## EBITDA\*

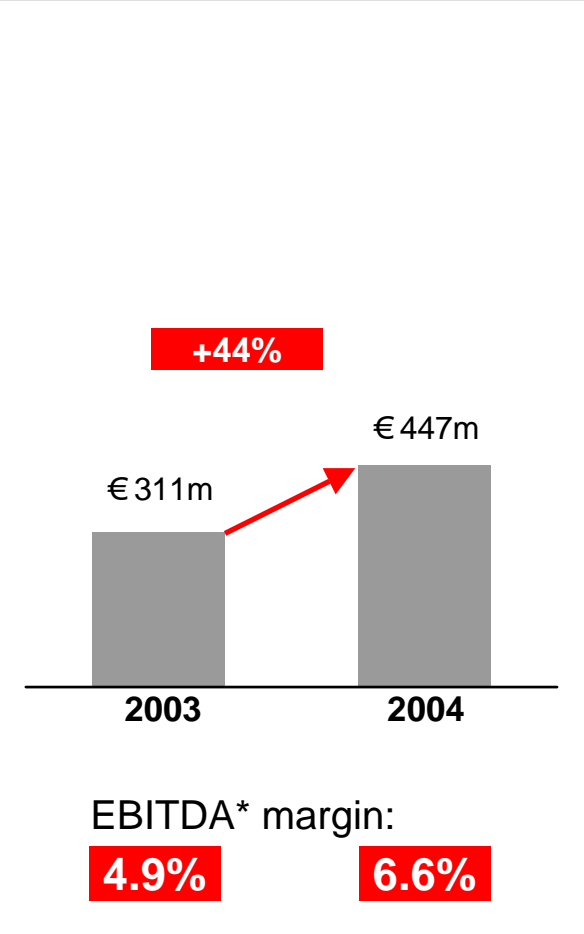

## Net earnings

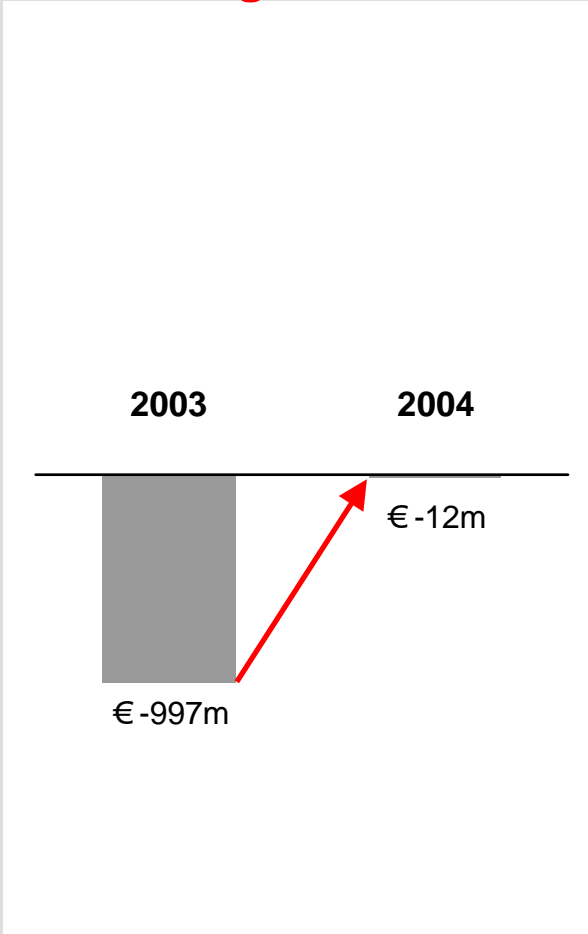

\* pre exceptionals

# Significantly Higher Sales in EMEA and Asia

**Sales by regions 2004**  
(in %)

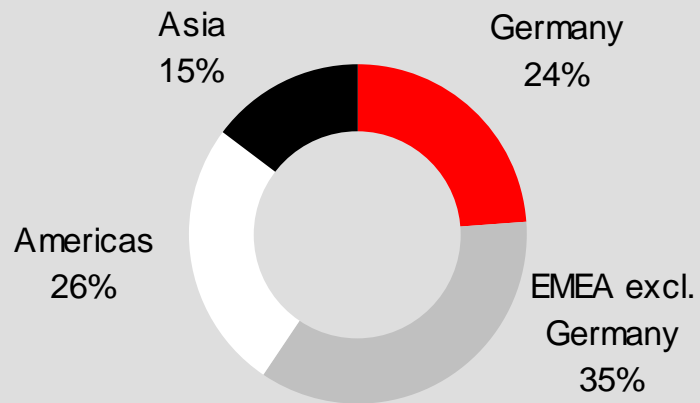

**Sales trend by region**  
(€million)

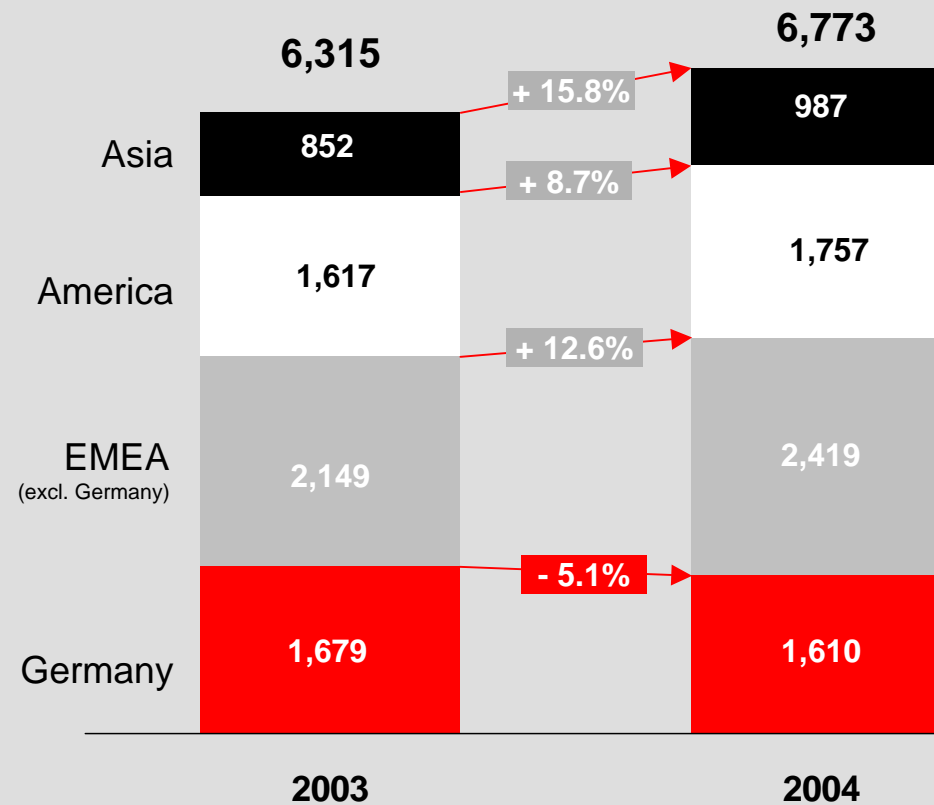

# Price- and Volume Increases Offset Unfavorable Currency Effects

(€ million)  
percentages rounded

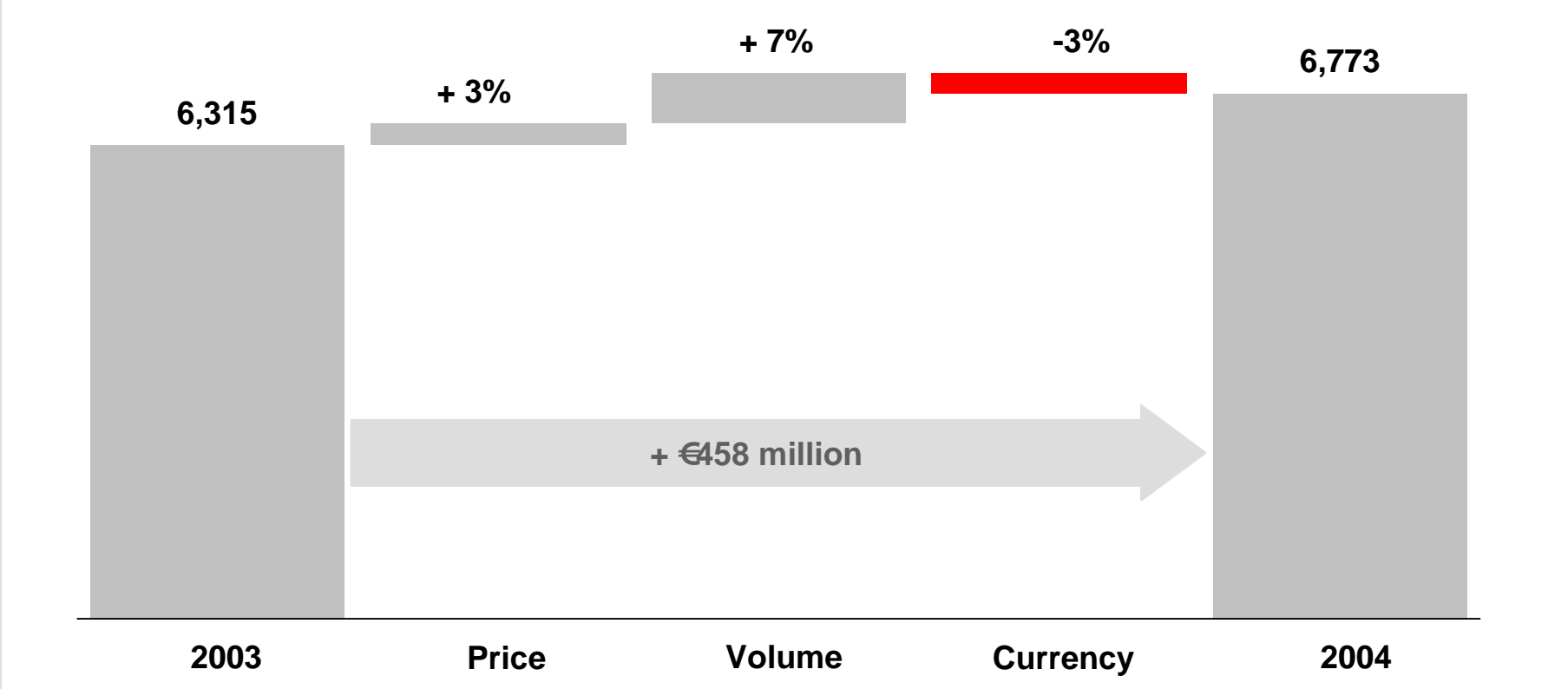

# Performance Rubber: Capitalizing on Market Leadership

## Example: PBR

- PBR and BTR organized in two separate business units for clearer business focus

- Results:

- Asset consolidation bearing fruit
- New price/volume strategy successfully implemented
- Utilizing our technology leadership to develop markets

## Turn Leadership Into Value

- Exploit growth potential
- Substantially increase profitability

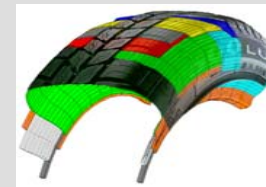

# Engineering Plastics: Focus on Restructuring

## Example: SCP

- Increase profitability by expanding capacities for intermediates
  - Higher volumes
  - Broadly similar cost structure
- Exploit growth potential in Asia
- Focus on customized compounding

## Turn Restructuring Into Value

- Utilize growth opportunities
- Reduce complexity
- Substantially increase profitability



# Chemical Intermediates: Utilizing our Asset Base

## Example: BAC

- Utilize our competitive, integrated production facilities to maintain our position in a consolidation scenario
- Maintain high capacity utilization to benefit from the economic upswing

## Turn Strong Asset Base Into Value

- Remain competitive against emerging Asian suppliers



# Performance Chemicals: Regional Expansion

## Examples: RCH, TPC, LEA

- Markets migrating to Asia
- Application engineering shifting to customers
  - RCH: Expansion of capacities in Qingdao
  - LEA: Technical service center and technology center opened in Wuxi
  - TPC: Expansion of technical expertise in Asia

## Turn Application Engineering Into Value

- Growth in profitable niche markets
- Regional expansion



# Agenda



1. Review of 2004
2. **FY 2004 Financials**
3. Strategy and Restructuring
4. Outlook



# Agenda



## **2. FY 2004 Financials**

### **2.1. Profit and Loss Statement: Overview, Exceptionals, Business Performance**

### **2.2. Balance Sheet**

### **2.3. Cash Flow**

### **2.4. Housekeeping**

# Nature of “Combined Financial Statements” (CFS)

- CFS reflect LANXESS’ historical financial performance as if spin-off had occurred on January 1, 2002 whereas discontinuing operations (“DO”) figures present LANXESS as integral part of the Bayer Group
- CFS also differ from “pro forma financials”, as historical CFS figures **do not reflect** the business as if LANXESS had been independent in the past (e.g. no adjustment for historical transfer prices)
- **Major assumptions\*** have been made regarding
  - Net debt and interest expense
  - Income taxes / Deferred taxes / Tax loss carry forwards
  - LANXESS Corporate Center

The absence of historical unity and independence of LANXESS limits the informative value of the CFS.

\*actual figures may differ from assumptions

**Differences between “DO” (Bayer reporting) and “CFS” (LANXESS reporting) will remain for full year 2004**

# Improvement in Full Year Results (CFS)

(€m)	FY 2003	FY 2004	Abs. chg.	Chg. in %
<b>Sales</b>	6,315	<b>6,773</b>	458	<b>7%</b>
Cost of goods sold	5,211	5,349	138	<b>3%</b>
SG&A	1,192	1,144	-48	-4%
R&D	168	123	-45	-27%
Other op. Result	-1,041	-98	943	91%
<b>EBIT</b>	<b>-1,297</b>	<b>59</b>	<b>1,356</b>	<b>n.m.</b>
thereof exceptionals	<b>-1,178</b>	<b>-99</b>	<b>-1,079</b>	<b>-92%</b>
<b>Net Income</b>	<b>-997</b>	<b>-12</b>	<b>985</b>	<b>99%</b>
EBITDA*	180	387	207	>100%
thereof exceptionals	-131	<b>-60</b>	-71	-54%
<b>EBITDA pre exceptionals</b>	<b>311</b>	<b>447</b>	<b>136</b>	<b>44%</b>

n.m.: not meaningful

\* EBITDA equals EBIT plus depreciation and amortisation

## 2004 Sales Variance by Segment (approximate numbers)

(€m)	FY 2003	Price	Volume	Currency	FY 2004
Performance Rubber	1,375	~ +4%	~ +3%	~ -3%	1,431
Engineering Plastics	1,401	~ +4%	~ +22%	~ -3%	1,722
Chem. Intermediates	1,411	~ +2%	~ +6%	~ -2%	1,487
Perf. Chemicals	1,925	~ -1%	~ +3%	~ -3%	1,910

(€m)	9M 2003	Price	Volume	Currency	9M 2004
Performance Rubber	1,038	~ +2%	~ +2%	~ -3%	1,046
Engineering Plastics	1,060	~ +0%	~ +24%	~ -3%	1,281
Chem. Intermediates	1,080	~ +0%	~ +4%	~ -2%	1,102
Perf. Chemicals	1,501	~ +1%	~ -1%	~ -3%	1,459

# Increased Raw Material Costs Were Mainly Passed Through

	(in € million)	Full year 2004	Price increase vs. 2003
<b>Full Year 2004</b>	<b>Net Sales</b>	6,773	160
	<b>COGS</b>	5,349	190

  
~80% of Raw Material price increase passed-through to customers in 2004

- Cost pass-through lags behind raw material price increases by ~3 months on average

**Q1/ Q2 2005**

Q1 2005: some relief in raw material cost pressure + selling price increases (announced in Q4 2004)

Q2 2005: rising raw material costs + time lag of ~ 3 months to increase selling prices

**Raw Material Prices are expected to remain on high levels during 2005**

# 2004 D&A and Exceptionals by Segment

(€m)	D&A 2004	thereof excep. D&A	total exceptionals
Performance Rubber	-61	0	-12
			Anti-Trust litigation TRP
Engineering Plastics	-37	3	3
		€24 m amendment to Impairment in STY -€21m Depreciation of capex in STY	
Chemical intermediates	-113	-22	-22
		€5 m Adjustment of '03 impairment in FCH -€27 m Depreciation of capex in FCH	
Performance Chemicals	-95	-20	-68
		-€20 m Goowill amortization RheinChemie	-€8 m anti-trust litigation RUC -€40 m environmental provision Merebank
Reconciliation	-22	0	0
<b>LANXESS Total</b>	<b>-328</b>	<b>-39</b>	<b>-99</b>

For 2003 D&A and Exceptionals by Segment, please see Back-up slides

# Performance Rubber: Improved Performance Despite Weak Q4 2004

(€m)	FY 2003	FY 2004
<b>Sales</b>	<b>1,375</b>	<b>1,431</b>
EBIT	-246	44
Depr. / Amort.	250	61
EBITDA	4	105
<b>EBITDA pre except.</b>	<b>36</b>	<b>117</b>
Margin	2.6%	<b>8.2%</b>
<b>Capex</b>	<b>78</b>	<b>76</b>

- Higher selling prices after increased raw material and energy costs as well as higher volumes in all BUs, especially in TRP more than offset negative currency effects
- Q4 impacted by costs for planned maintenance shutdowns
- Provisions in connection with settlement of antitrust investigations of €12 m mainly in TRP negatively affected EBIT and EBITDA

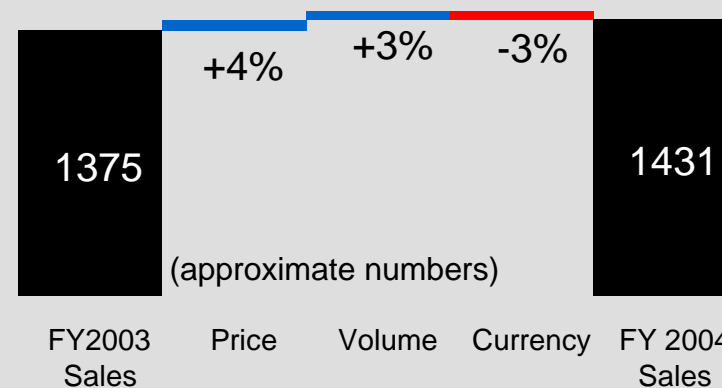
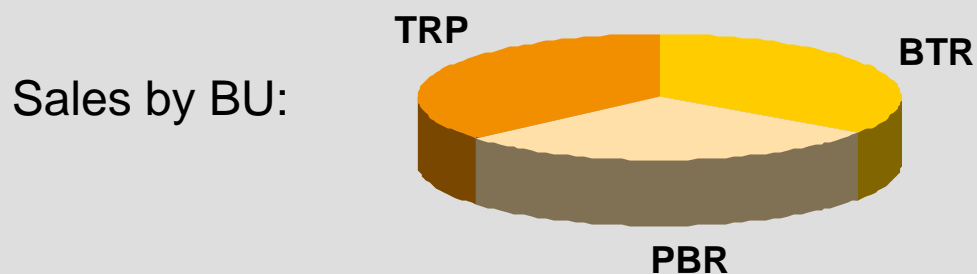

# Engineering Plastics: Reasonable Improvement vs. Prior Year But Still the Lagging Segment

(€m)	FY 2003	FY 2004
<b>Sales</b>	<b>1,401</b>	<b>1,722</b>
EBIT	-488	7
Depr. / Amort.	474	37
EBITDA	-14	44
<b>EBITDA pre except.</b>	<b>22</b>	<b>44</b>
Margin	1.6%	2.6%
<b>Capex</b>	<b>85</b>	<b>45</b>

- Sales increased on higher volumes and to some extent prices in SCP and partly STY. Sales in FIB were lower due to continuing overcapacities and corresponding price pressure
- EBITDA improved on higher sales and a partial pass-through of higher raw material prices
- Continued prudent Capex approach

Sales by BU:

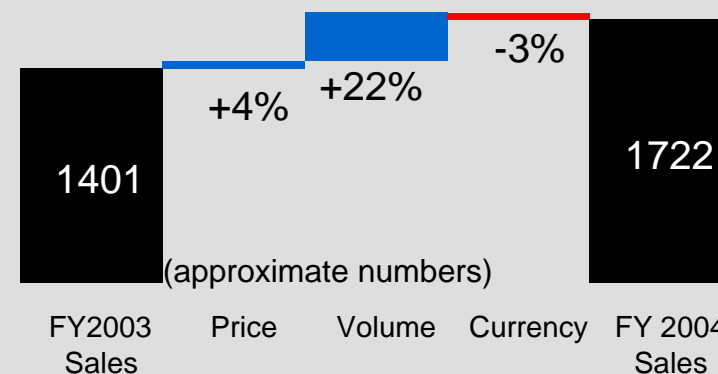
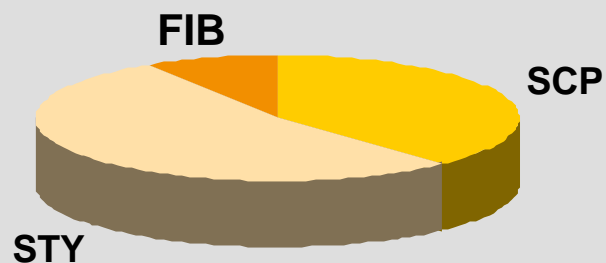



# Chemical Intermediates: BAC and IPG Overcompensate Weak FCH Performance

(€m)	FY 2003	FY 2004
<b>Sales</b>	<b>1,411</b>	<b>1,487</b>
EBIT	-344	65
Depr. / Amort.	463	113
EBITDA	119	178
<b>EBITDA pre except.</b>	<b>153</b>	<b>178</b>
Margin	10.8%	12.0%
<b>Capex</b>	<b>79</b>	<b>89</b>

- Sales growth in BAC and IPG due to higher volumes and increased prices after risen raw material costs
- FCH sales were lower since improved sales in agrochemicals did not offset effects from continued difficult market conditions especially in photo chemicals
- Net impairments of €22 million consisting of €27 million impairment and €5million write-back weighed on EBIT

Sales by BU:

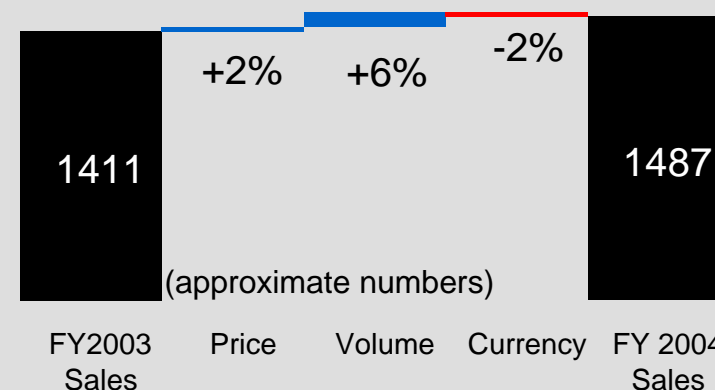
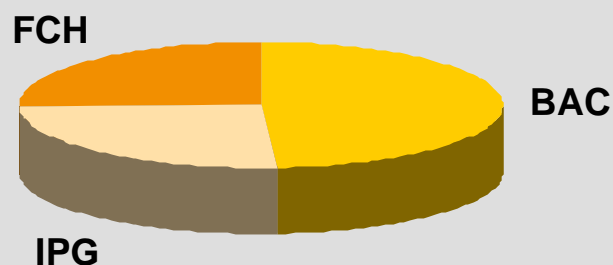

# Performance Chemicals: No Performance Improvement due to Selling Price Pressure and Difficult Businesses

(€m)	FY 2003	FY 2004
<b>Sales</b>	<b>1,925</b>	<b>1,910</b>
EBIT	-176	-20
Depr. / Amort.	272	95
EBITDA	96	75
<b>EBITDA pre except.</b>	<b>125</b>	<b>123</b>
Margin	6.5%	6.4%
<b>Capex</b>	<b>63</b>	<b>57</b>

- Total sales were slightly lower
  - increases in RCH, LEA, ION and MPP almost offset decreases in the remaining BUs, mainly FCC and TPC
- Positive volume effects offset unfavorable currency impacts
  - sales however slightly decreased due to pricing pressure

Sales by BU:

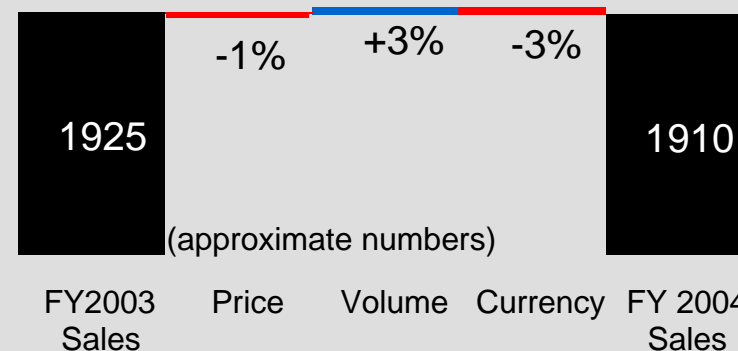
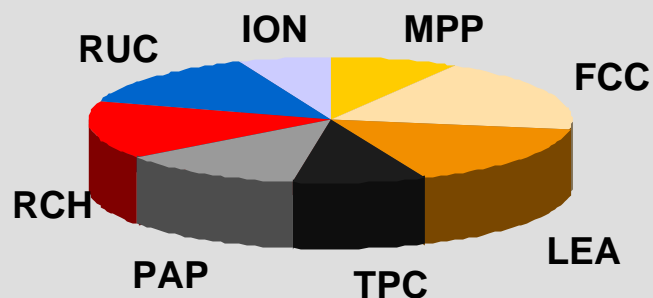

# Agenda



## 2. Financial Content

**2.1. Profit and Loss Statement:  
Overview, Exceptionals, Business Performance**

**2.2. Balance Sheet**

**2.3. Cash Flow**

**2.4. Housekeeping**

# Condensed Consolidated Balance Sheet

(€ m)	Dec 31, 2003	Dec 31, 2004	(€ m)	Dec 31, 2003	Dec 31, 2004
<b>Non-current Assets</b>			<b>Shareholders' equity</b>	1,358	1,331
Intangible assets	99	65	<b>Minority stockholders' interest</b>	43	34
Property, plant & equipment	1,551	1,521	<b>Provisions</b>		
Investments	40	85	Pension & post empl. provisions	408	418
			Other provisions	405	481
<b>Current Assets</b>			<b>Liabilities</b>		
<b>Inventories</b>	1,096	1,151	Financial obligations	1,442	1,207
<b>Trade receivables</b>	990	1,137	thereof Mandatory Convertible	-	200
Loan to Bayer	256	0	<b>Trade accounts payable</b>	574	820
Other receivables & assets	298	363	Misc. liabilities	187	189
Cash & cash equivalents	13	72	<b>Deferred taxes</b>	57	55
<b>Deferred taxes</b>	170	172	<b>Deferred income</b>	56	41
<b>Deferred charges</b>	18	11	<b>Total Liabilities &amp; Equity</b>	4,531	4,577
<b>Total assets</b>	4,531	4,577			

# Differences Between Assumptions in CFS and Reality Lead to Effects in LXS Deferred Tax Assets and Therefore in LXS Shareholder Equity

- Background**
- Bayer's assumptions in the CFS: ~€540 million tax loss carry forwards (~€216\* million deferred tax asset) related primarily to impairments in 2003 were allocated to LANXESS as per December 31st, 2004 for Germany
  - Following German tax law eventually finally only ~6.3% of Bayer AG's total tax loss carry forward (~€33 million deferred tax asset) are transferred to LANXESS AG in the course of the spin-off. The respective deferred tax asset must be adjusted by approximately -€185 million (FY 2004 vs. Q1 2005)
  - Additional differences lead to further reduction of the respective deferred tax asset. The total delta amounts to appr. -€250 million. (FY 2004 vs. Q1 2005)

---

## Effects

- Technical reduction of the balance sheet
- Equity will be reduced by appr. €250 million as of January 1st, 2005
- P&L will not be impacted
- Cash flow will not be impacted

**Standard and Poor's: "No effect on investment grade rating"**

\*The balance sheet shows €172m which is an amount net of certain deferred tax liabilities

# Net Financial Debt Reduced and Maturity Profile to Become More Balanced

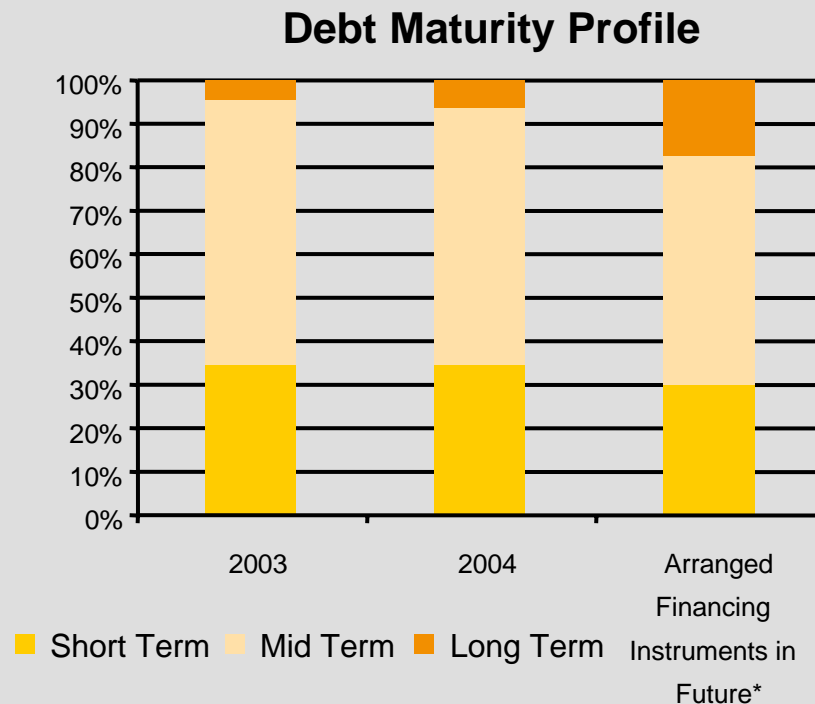
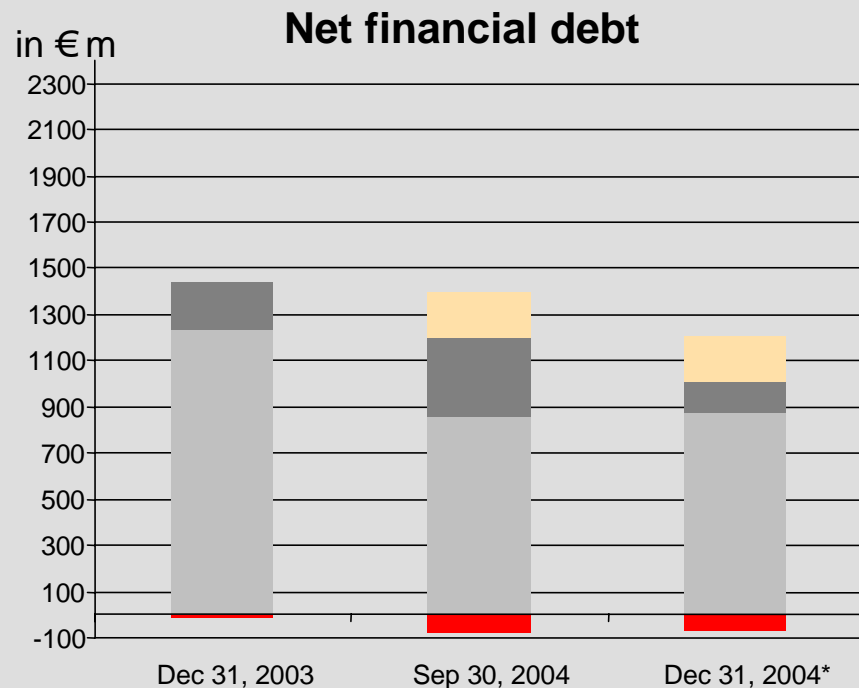

■ Cash ■ Short/ Mid-term liability ■ Long term liability ■ Convertible

– **Additional financing headroom of ~€1bn established**

– **Net financial debt includes effect from €130 million payment term adjustment with Bayer**

– **Planned Euro bond will improve debt maturity structure in the future**

Net financial debt excluding pensions: financial obligations (including convertible) less cash & cash equivalents

\* Maturity profile of actually drawn financing instruments will likely have an even larger long-term portion

# Working Capital\* Reduced by Year End Mainly due to Payment-Term Negotiation with Bayer

in €m

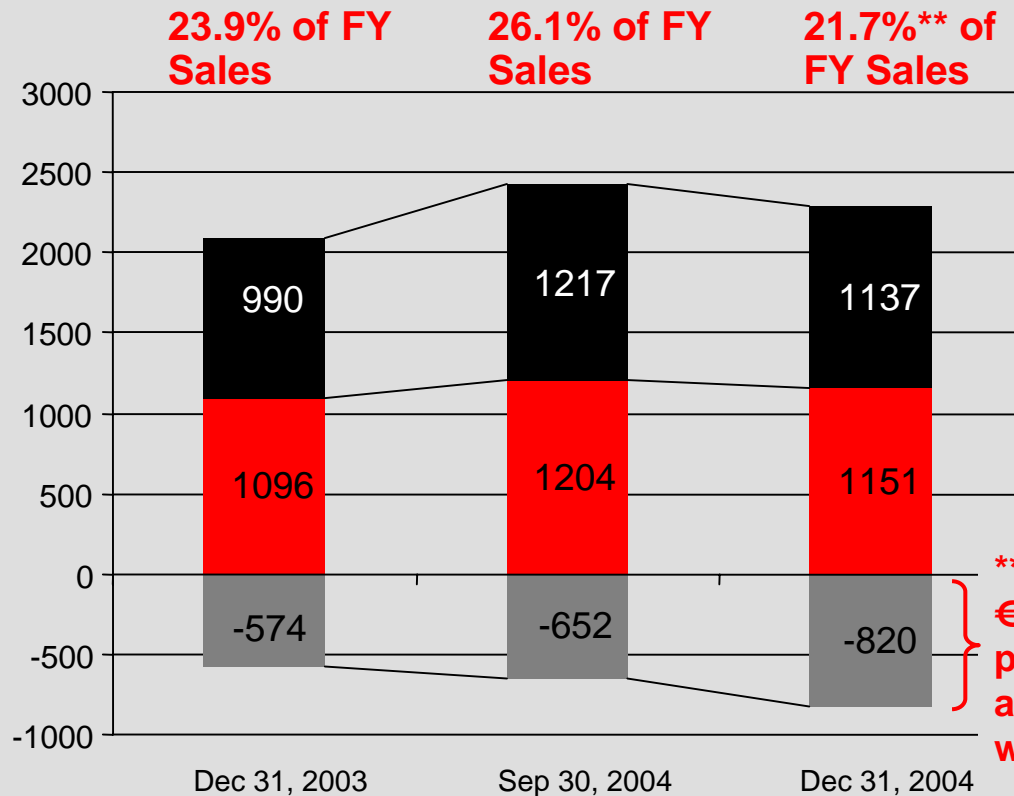

## YoY - Change:

- Inventory: Planned maintenance shutdowns and price increases as well as system migration in the US impacted inventory
- Receivables: Higher sales especially in Q3 2004 and Q4 result in increased trade receivables
- Payables: Increased raw material prices and higher volumes impact payables
- Working Capital is expected to remain above 20% of sales

**Target until 2006: Counterbalance €130 m increase from expiry of payment term adjustment**

\* Working Capital : Inventory plus trade accounts receivable less trade accounts payable

# Agenda



## 2. Financial Content

**2.1. Profit and Loss Statement:  
Overview, Exceptionals, Business Performance**

**2.2. Balance Sheet**

**2.3. Cash Flow**

**2.4. Housekeeping**



# Essential for Future: Strong Cash Flow Generation

(€m)	FY 2003	FY 2004
<b>EBIT</b>	<b>-1,297</b>	<b>59</b>
Taxes Paid	12	-45
Depreciation & Amortization	1477	328
Change in Pension Accrual	25	-31
Gain/ Loss from Sale of Assets	6	2
Change in Working Capital*	16	-35
Change in other current assets	107	33
<b>Net cash provided by operating act.</b>	<b>346</b>	<b>311</b>
<b>Capex</b>	<b>-312</b>	<b>-279</b>
Cash Flow used in investing activities**	-300	-39
Cash Flow used in financing activities	-46	-214
Cash at End of Period	13	72

- Higher taxation due to higher taxable income and certain amounts of non-deductible tax items
- Working Capital increases due to increased sales, risen raw material costs and planned maintenance shut-downs

**Restructuring expected to impact cash flow in 2005/2006**

\* Working Capital : Inventory plus trade accounts receivable less trade accounts payable

\*\* including repayment of loan to Bayer in 2004

# Disciplined Approach for Capital Expenditures

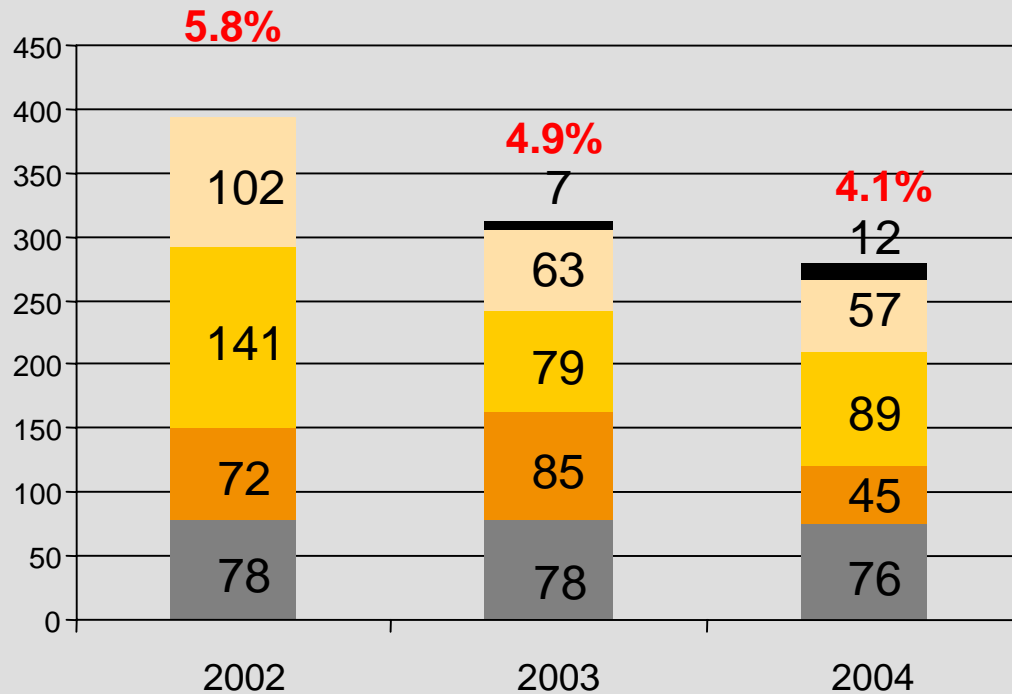

LANXESS rule of thumb for Capex split:

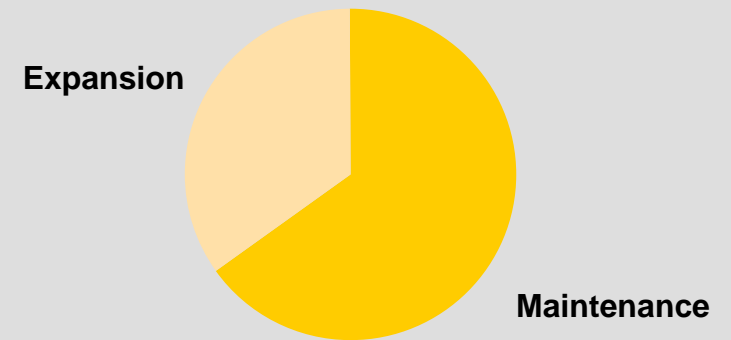

**Annual Capex for next 2 years expected ~4% of sales**

Percentages: Capex in % of sales

# Agenda



## 2. Financial Content

**2.1. Profit and Loss Statement:  
Overview, Exceptionals, Business Performance**

**2.2. Balance Sheet**

**2.3. Cash Flow**



**2.4. Housekeeping**

# LANXESS LTIP's on Board Level: Stock Performance Plan (SPP) and Economic Value Plan (EVP)

- **Condition to participation: Personal investment (40% of one annual fixed salary in three tranches)**
- **Stock Performance Plan (SPP)**
  - **Benchmark:** Outperformance of the DJ global STOXX 600 Chemicals index (index+10%:100% targeted payout, index+20%: cap and maximum payout)
  - **Targeted payout\*:** 90% of one total annual salary (fixed and variable)
  - **Vesting period:** 3 years, following 2 years of exercise period for each tranche
  - **Blackout periods:** surrounding earnings releases and AGM
  - **Grant price:** volume weighted average of first ten trading days (€15.01 for first tranche)
- **Economic Value Plan (EVP)**
  - **Benchmark:** Increase of Economic Value over three years ('04-'07, '05-'08, '06-'09) according to business plan  
Economic Value = EBITDA \* Multiplier, less net debt
  - **Targeted payout\*:** 40% of one total annual salary
  - **Vesting period:** 3 years, automatic exercise after 3 years
- **Accounting treatment:** Value calculated by option pricing model (Black-Scholes) will be expensed over three years for each tranche.

\* percentage applicable on Board level - lower percentage for first level below Board of Management

# We Start with Realistic Targets

	2003 Target***	2004 Target***	2006
<b>EBITDA* Margin</b>	< 5%	~ 7% 	9 – 10%
<b>Capex/Sales</b>	~ 5%	4 – 5% 	~ 4%
<b>Net Financial Debt**/EBITDA*</b>	~ 4.5	< 3 	< 2.5

**Guidances given prior to listing were achieved**

\* Excluding exceptionals  
 \*\* Net financial debt excluding pensions: financial obligations (including convertible) less cash & cash equivalents  
 \*\*\* The financial targets do not include any impact of potential divestments

# Agenda



1. Review of 2004
2. Financial Content
3. Strategy and Restructuring
4. Outlook

# Step-by-Step Approach to Creating Value

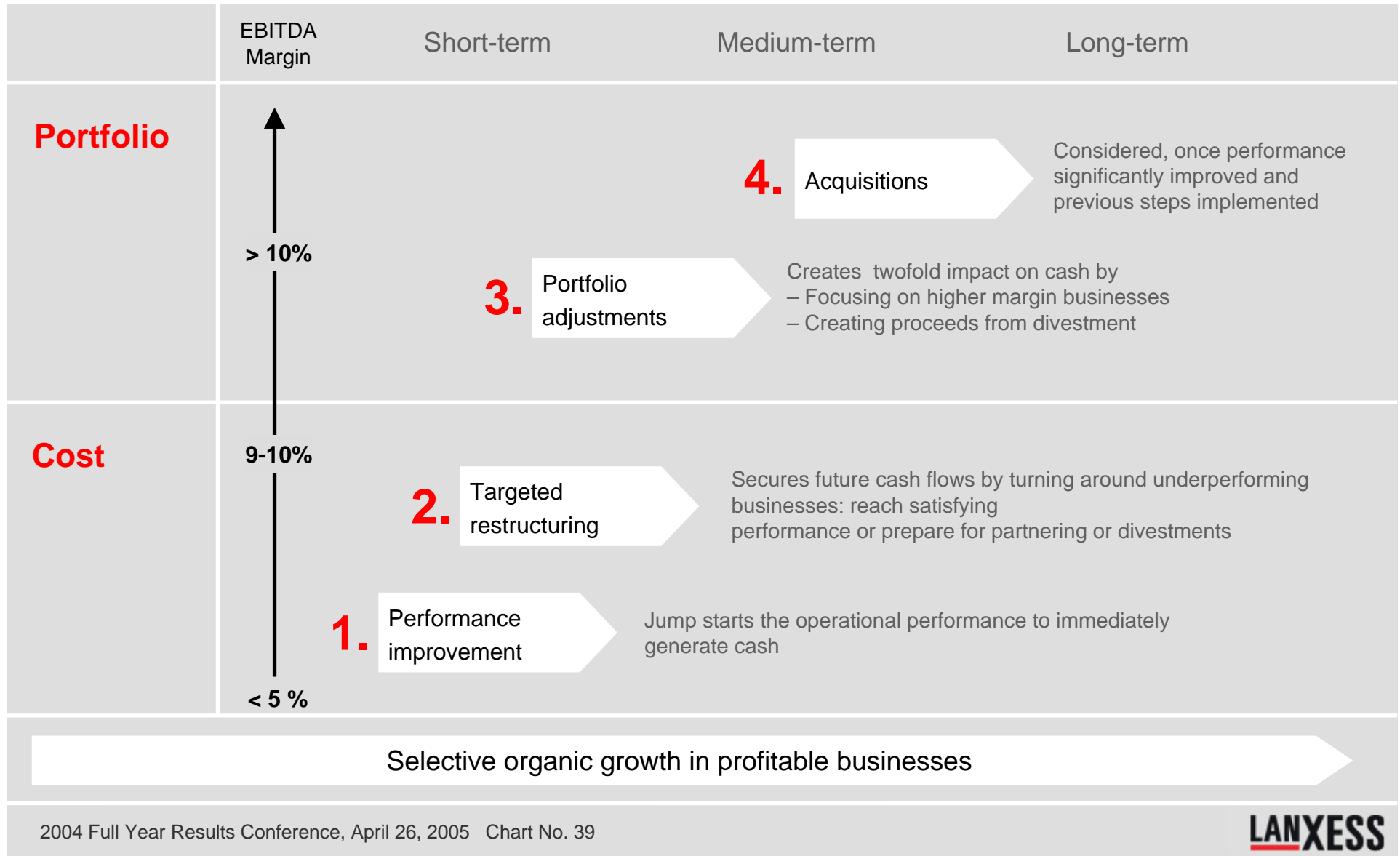

## 2. Targeted Restructuring in Problem Areas

### Profitability distribution LANXESS

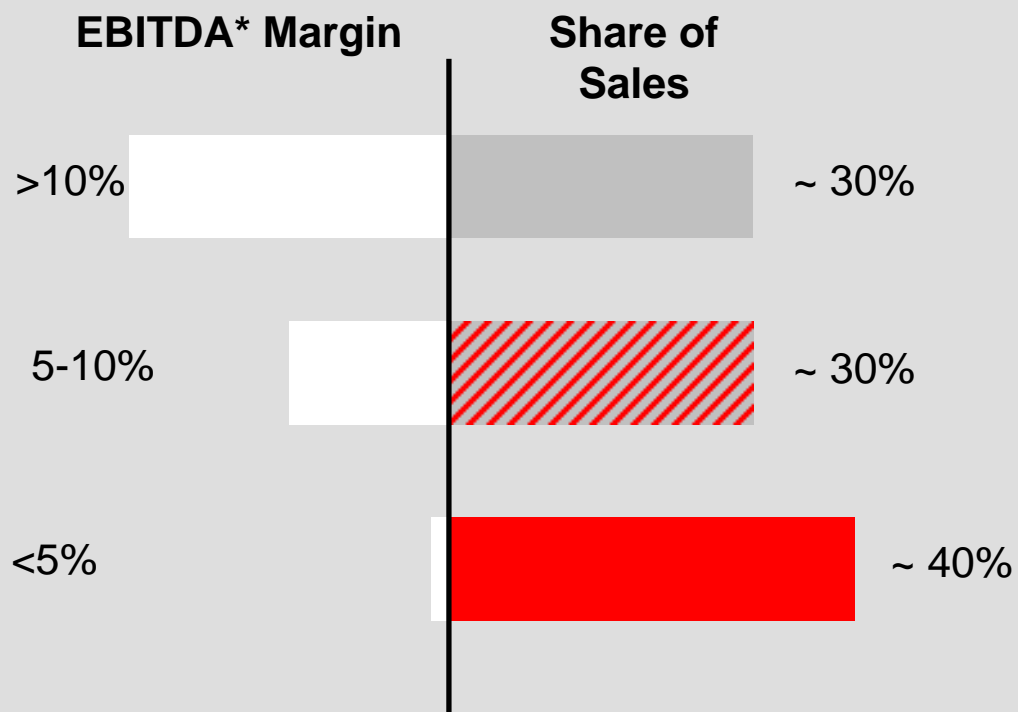

### Action programs

- Volume/price strategy
- Cost containment, efficiency improvement
- Large-scale restructuring
- Portfolio options

\* pre exceptionals



# Engineering Plastics – Styrenic Resins



# New Capacities and Customers in Asia

## Market trend STY

- Global market growth around 6%, double-digit increases in China and India
- Global capacity increasing by about 5% a year (China approx. 14% )
- Customer industries shifting to China
- Some segments showing rapid growth, particularly specialties

## Customer industries

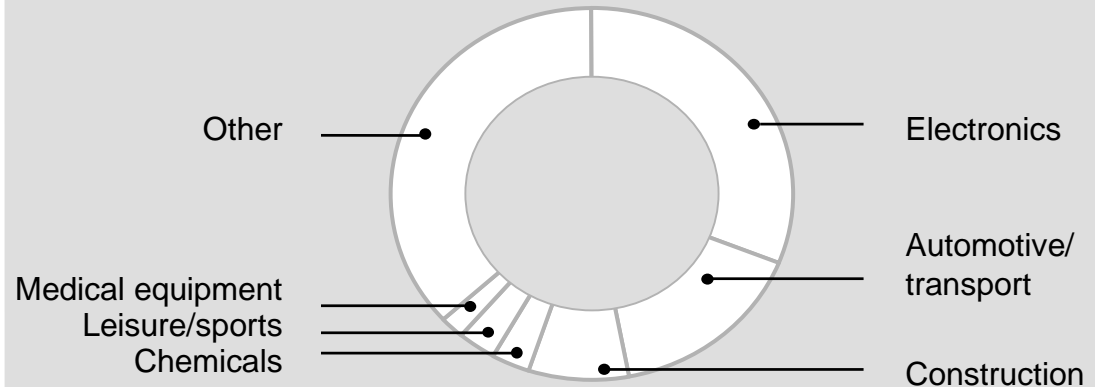

## Product examples



# Growth Strategy in Europe Offers No Prospect of Success

## Earnings trend in Europe

- Heavy losses in Europe for years
- Earnings still negative despite recovery in 2004
- Intense competitive pressure from Asia for standard grades

## Growth rates (p.a.)

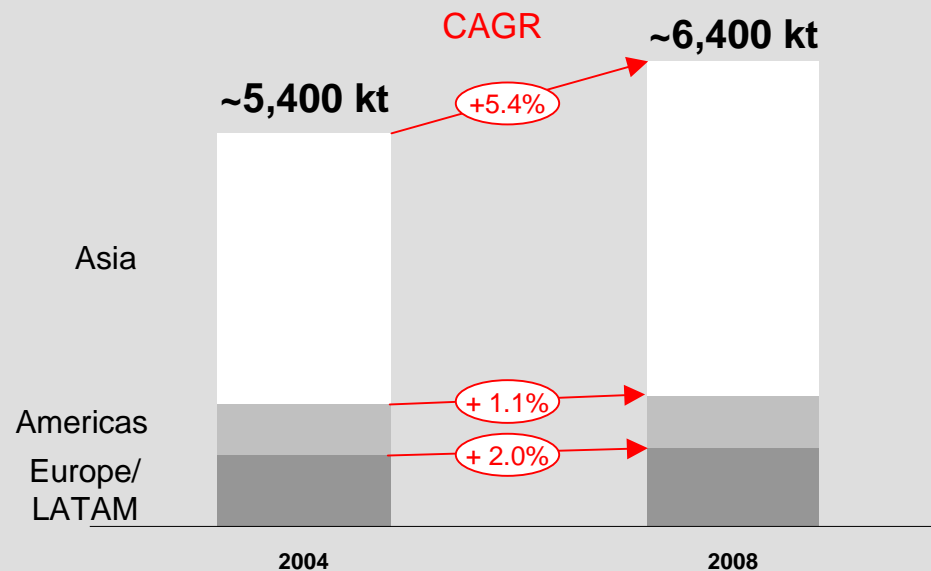

Volume-Growth-Strategy not viable in Europe

# Only One European Facility Can Survive

## Need for action in Europe

- LXS not competitive in standard grades
- Specialties are core business
- Marketing of unprofitable products to be discontinued
- Asset consolidation results in only one fully loaded plant
- Most competitive site - either Dormagen or Tarragona - will survive

## Asset consolidation

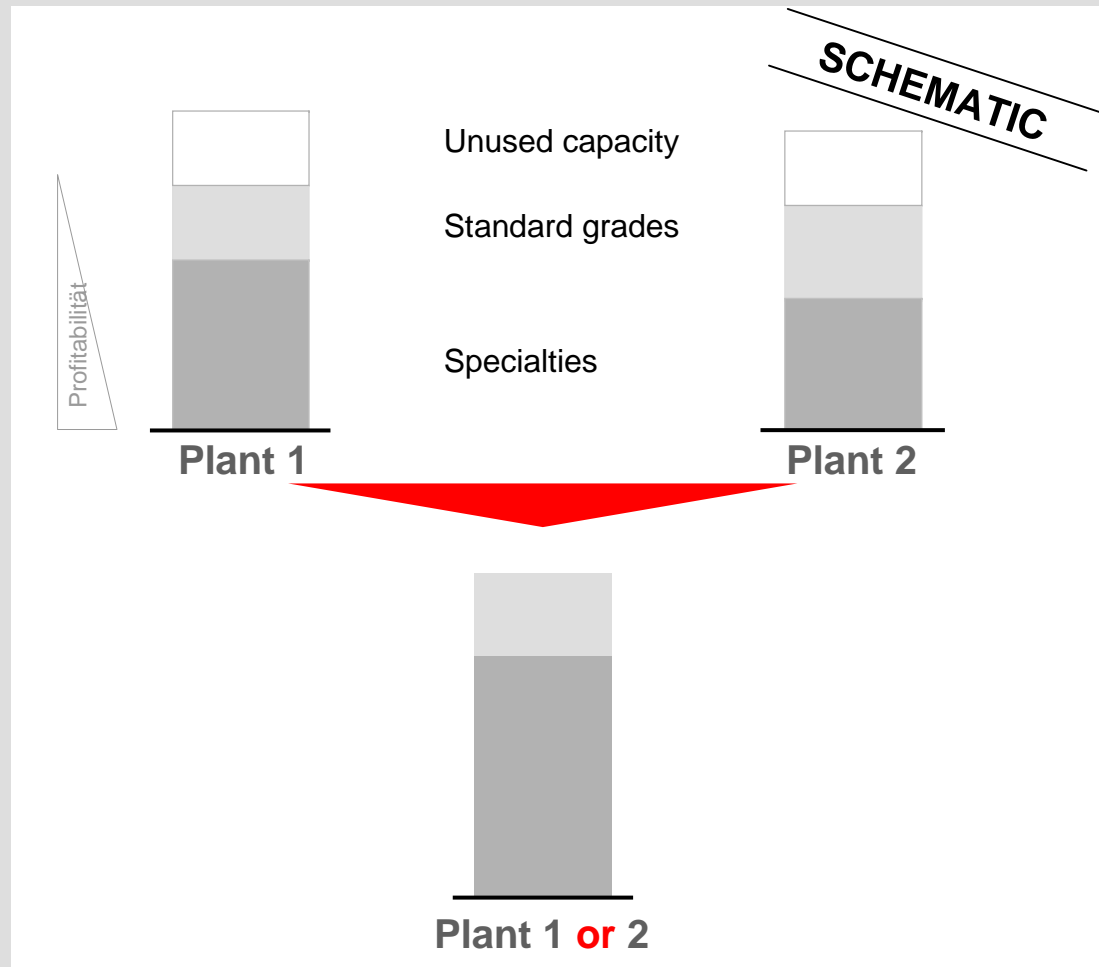

## Chemical Intermediates – FCH

**LANXESS**

# Overcapacities and Asian Competition Are Driving Consolidation

## Market trend FCH

- Pharma market suffering from overcapacities
- Increasing Asian competition
- Price erosion in all segments
- Continuing consolidation

## FCH Customer industries

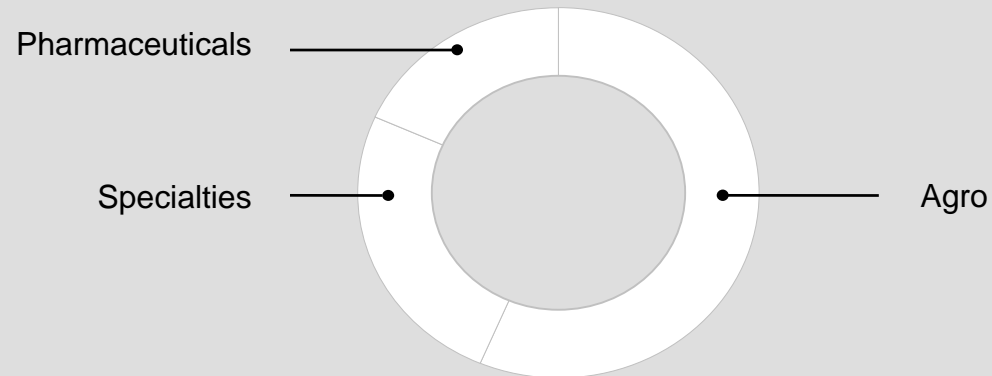

## Product spectrum

- BU offers custom manufacturing services
- Manufactures customized intermediates and active ingredients for agrochemical, pharmaceutical and other industries

# Continuing Loss of Sales to Bayer-Businesses

## Situation in FCH

- Steady losses for five years
- Declining sales
- LANXESS is subsidizing FCH

## Problem areas in FCH

- Market overcapacities
- Continuing drop in sales to (former) Bayer problem businesses
- Capacities underutilized
- Inefficient processes

## Sales

New business

Bayer and former Bayer business

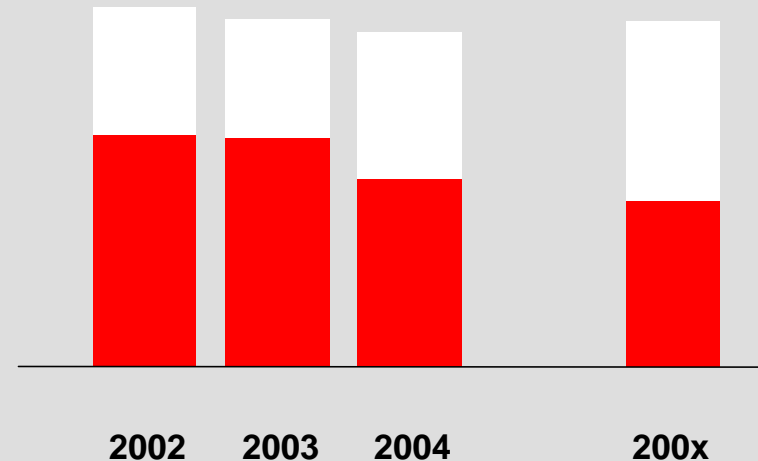

# Markets for FCH are Basically Attractive

## Situation in FCH markets

- Market has offered high margins for some years
- Market still showing slight growth
- Success in this business depends on having the right structures
- Competitors are benchmark companies that demand high margins
- FCH is one of the “worst 2”

## EBITDA in % of Sales

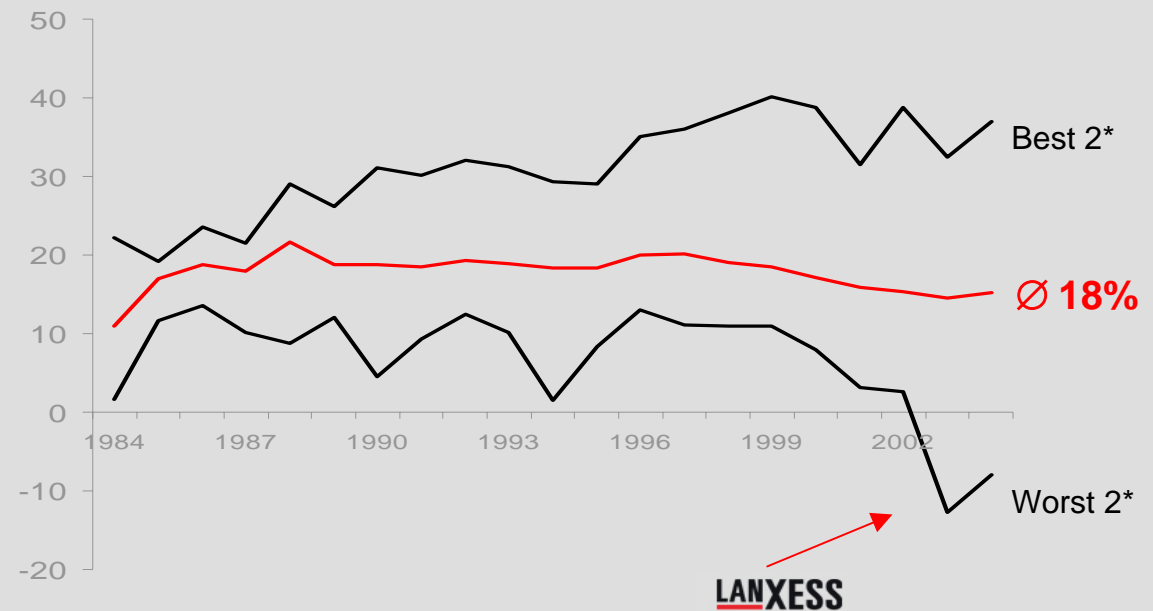



# Concentration on competitive facilities

## FCH model

Concentrate on profitable projects



- Expand sales force
- Reduce production base / process development
- Concentrate on competitive facilities



**Survival**

# Restructuring Styrenics and Fine Chemicals to become competitive

**Focus on more competitive structure and jobs in Europe**

**Streamline current setup -  
up to 1,200 jobs at risk**

**Despite unfavorable labor agreements  
talks with workers' councils already started**

# 3. Portfolio Adjustment

**3.** Portfolio-  
adjustment

- Portfolio adjustments form the third stage of the program for sustainable competitiveness
- LANXESS open to discussions
- Search for a partner for PAP has begun

# Agenda



- 1. Review of 2004**
- 2. Financial Content**
- 3. Strategy and Restructuring**
- 4. Outlook**

# Outlook for 2005

## Economy

- Continuing moderate growth worldwide
- Still on the upside of the chemicals cycle

## Market conditions

- Strong Euro
- High raw material costs
- Fierce competition in many areas

## LANXESS

- Necessary restructuring a major challenge
- Positive effect of
  - Operational improvements
  - Portfolio management

**LANXESS**

Energizing Chemistry

**INDEPENDENT. SOVEREIGN. AUTONOMOUS.  
PERFORMANCE DRIVEN SET-UP.  
SIGNIFICANT GLOBAL PLAYER.  
CLEAR STRATEGY FOR VALUE GENERATION.  
DISCIPLINED CASH MANAGEMENT.**





# Appendix



# Built on Polymers and Chemicals



Performance  
Rubber



Engineering  
Plastics



Chemical  
Intermediates



Performance  
Chemicals



Independence. Cost Reduction. Portfolio Management.

# Entrepreneurial and Experienced Board Directly Connected to BUs

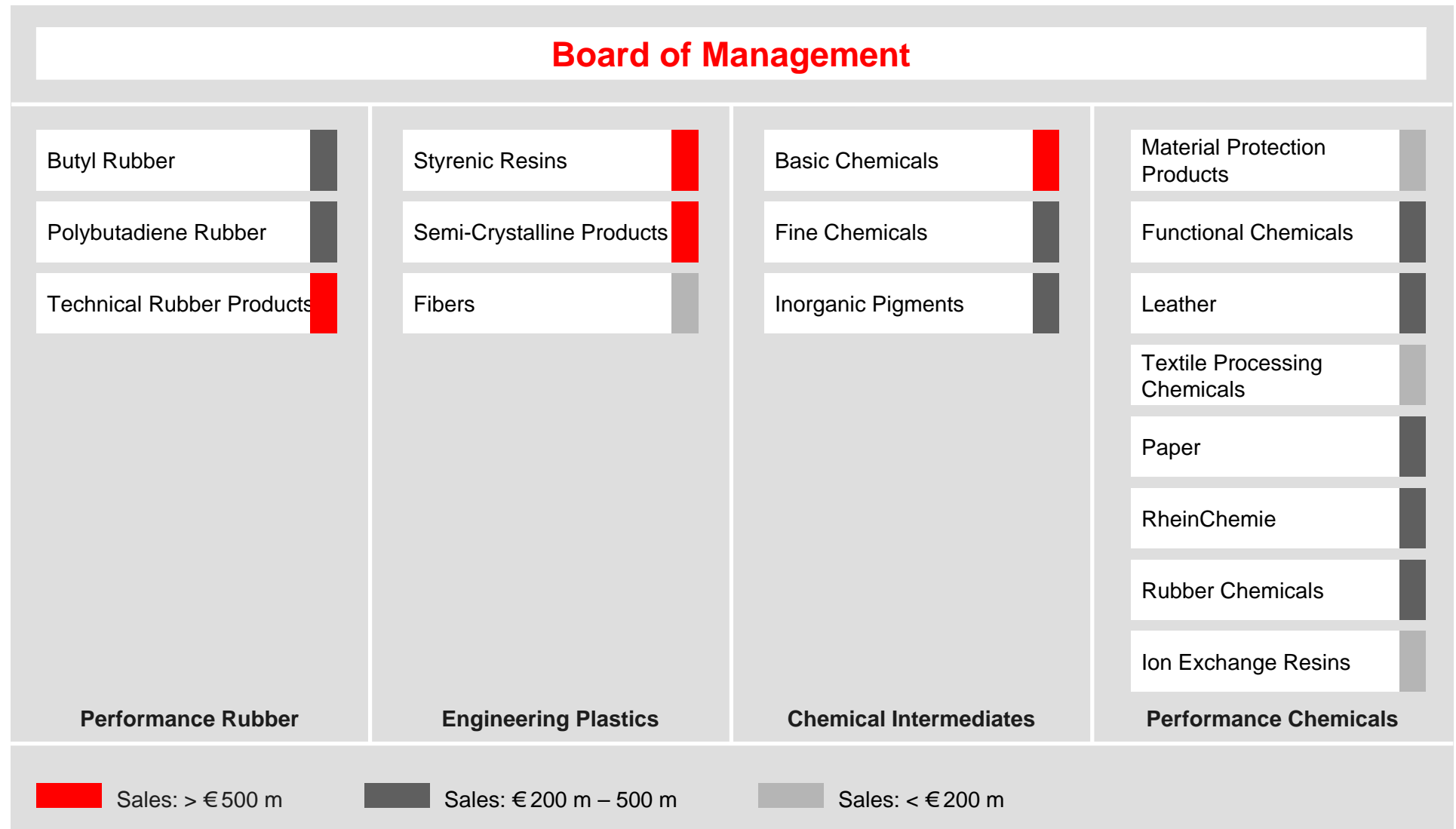

# Q4 Results (CFS)

(€m)	Q4 2003	Q4 2004	Abs. chg.	Chg. in %
<b>Sales</b>	<b>1,487</b>	<b>1,726</b>	<b>239</b>	<b>16%</b>
Cost of goods sold	1,292	1,412	120	9%
SG&A	347	310	-37	-11%
R&D	50	28	-22	-44%
Other op. Result	-1,018	7	1,025	n.m.
<b>EBIT</b>	<b>-1,220</b>	<b>-17</b>	<b>1,203</b>	<b>99%</b>
thereof exceptionals	<b>-1,136</b>	<b>-18</b>	<b>-1,118</b>	<b>-98%</b>
<b>Net Income</b>	<b>-884</b>	<b>-4</b>	<b>880</b>	<b>&gt;100%</b>
EBITDA*	-120	62	182	>100%
thereof exceptionals	-106	-	106	100%
<b>EBITDA pre exceptionals</b>	<b>-14</b>	<b>62</b>	<b>76</b>	<b>&gt;100%</b>

n.m.: not meaningful

\* EBITDA equals EBIT plus depreciation and amortisation

# Exceptional overview in Full Year Results (CFS)

(€m)	FY 2003		FY 2004
<b>Sales</b>	<b>6,315</b>		<b>6,773</b>
Cost of goods sold	5,211	Operating costs include remaining €163 M of exceptionals	5,349
SG&A	1,192		1,144
R&D	168		123
Other op. Result	-1,041	Thereof €1,015 Mio exceptionals	-98
			Thereof €99 Mio exceptionals
<b>EBIT</b>	<b>-1,297</b>		<b>59</b>
thereof exceptionals	-1,178		-99
<b>Net Income</b>	<b>-997</b>		<b>-12</b>

## 2003 D&A and Exceptionals by Segment

(€m)	D&A 2003	thereof excep. D&A	total exceptionals
Performance Rubber	-250	-159	-191
Engineering Plastics	-474	-372	-408
Chemical intermediates	-463	-332	-366
Performance Chemicals	-272	-171	-200
Reconciliation	-18	-13	-13
<b>LANXESS Total</b>	<b>-1,477</b>	<b>-1,047</b>	<b>-1,178</b>

# Performance Rubber: Relatively Weak Fourth Quarter

(€m)	Q4 2003	Q4 2004
<b>Sales</b>	<b>337</b>	<b>385</b>
EBIT	-195	2
Depr. / Amort.	162	6
EBITDA	-33	8
<b>EBITDA pre except.</b>	<b>-12</b>	<b>8</b>
Margin	n.m.	2.1%
<b>Capex</b>	<b>30</b>	<b>33</b>

# Engineering Plastics: Strong Volume and Price Increases in the Fourth Quarter

(€m)	Q4 2003	Q4 2004
<b>Sales</b>	<b>341</b>	<b>441</b>
EBIT	-431	-9
Depr. / Amort.	385	15
EBITDA	-46	6
<b>EBITDA pre except.</b>	<b>-20</b>	<b>6</b>
Margin	n.m.	1.4%
<b>Capex</b>	<b>32</b>	<b>19</b>

## Chemical Intermediates: BAC and IPG Overcompensate Weaker FCH Performance

(€m)	Q4 2003	Q4 2004
<b>Sales</b>	<b>331</b>	<b>385</b>
EBIT	-377	19
Depr. / Amort.	357	27
EBITDA	-20	46
<b>EBITDA pre except.</b>	<b>14</b>	<b>46</b>
Margin	4.2%	11.9%
<b>Capex</b>	<b>30</b>	<b>36</b>



# Performance Chemicals: Flat Performance Mainly due to Pricing Pressure and Unfavorable Currency Effects

(€m)	Q4 2003	Q4 2004
<b>Sales</b>	<b>424</b>	<b>451</b>
EBIT	-227	-12
Depr. / Amort.	192	19
EBITDA	-35	7
<b>EBITDA pre except.</b>	<b>-10</b>	<b>7</b>
Margin	n.m.	1.6%
<b>Capex</b>	<b>24</b>	<b>24</b>

# Sales by Region

**2003**

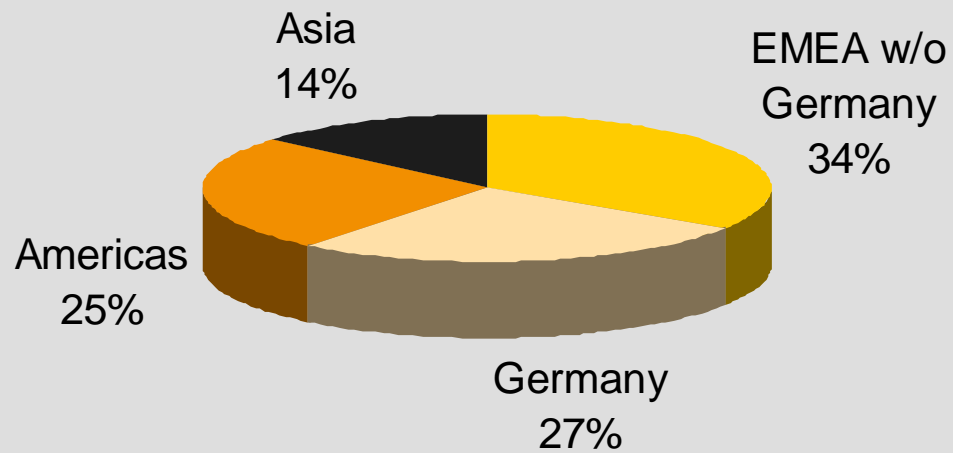

**2004**

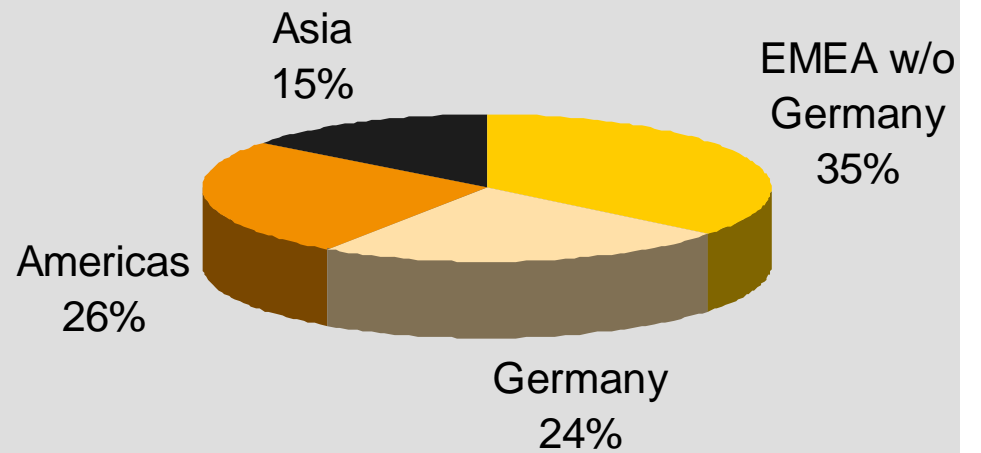

# Hedging Policy

## Currency Hedging

- 100% coverage of anticipated receivables and payables
- €800 - €900 million FX exposure mainly to USD (~€450 million) - thereof ~30% hedged

## Raw Material and Energy Hedging

- active in energy hedging
- no significant raw material hedging right now

# First Feedback on 2005

- **Business view:**
  - Q1 2005 started reasonably good - favorable pricing, supporting ease of raw material costs - however March already showed rising raw materials again
  - Restructuring efforts are expected to burden both, P&L and cash flow in course of 2005 and 2006
  
- **Business environment:**
  - The chemical cycle is expected to continue to be supportive
  - Raw materials and energy expected to remain at high levels

**First Guidance on 2005 will be given with release of Q1 2005 results**

# Contact Details

## **Michael Pontzen (Head of IR)**

Tel.: +49-214 30 43804

Fax.: +49-214 30 96 43804

Mobile: +49-175 30 43804

michael.pontzen@lanxess.com

## **Oliver Stratmann**

+49-214 30 49611

+49-214 30 96 49611

+49-175 30 49611

oliver.stratmann@lanxess.com

## **Tanja Satzer**

Tel.: +49-214 30 43801

Fax.: +49-214 30 96 43801

Mobile: -

tanja.satzer@lanxess.com

## **Dr. Gerd Zelesny**

+49-214 30 71416

+49-214 30 96 71416

+49-175 30 71416

gerd.zelesny@lanxess.com

Please visit our website at: [www.lanxess.com](http://www.lanxess.com)

## **Next important Dates:**

**May 31:**

**Q1 results**

**June 16:**

**AGM**

**August 25:**

**Q2 results**

**November 17:**

**Q3 results**